

Product Information LAR-361 | LAR-761 FOOD

# Climatic Independent Level Sensor LAR



### Application / Specified usage

- Hydrostatic level measurement in humid ambience
- Special applicable for exterior storage vessels

### Application examples

- Level measurement with LAR, linearization and evaluation with PEM-DD (6 standard geometries, 1 geometry programmable; see separate product information)
- Difference pressure measurement with 2 x LAR and evaluation device PEM-DD

### Hygienic design / Process connection

- By using the Negele weld-in sleeve EMZ-352 or the build-in system EHG-.../1" a front-flush, hygienic and easy cleanable measurement point will be achieved.
- EHEDG certificate for hygienic process connection CLEANadapt (LAR-361)
- Conforming to 3-A Sanitary Standard for versions with Tri-Clamp DIRECTadapt (LAR-761)
- CIP-/ SIP-cleaning up to 140 °C (284 °F) / max. 30 min
- Front-flush stainless steel sensor cell
- All wetted materials are FDA-conform
- Sensor completely made of stainless steel
- Protection class IP 69 K (with cable connection)
- Available process connections (adapter): Tri-Clamp, SMS, DRD, Varivent, BioControl

### Features / Advantages

- Measurement cell without any contact to atmosphere, fully closed measurement system
- No drift problems caused by condensation
- Very high accuracy and long term stability
- Measurement up to 130 °C (265 °F) medium temperature
- Oil filling, FDA approved
- Factory or field calibration
- Integrated two-wire measurement transducer 4...20 mA
- 3 years warranty**

### Options / Accessories

- Material certificate 3.1
- Special pressure ranges, specific pressure calibration ex works
- Electrical connection with M12 plug-in connector
- Preassembled cable for M12 plug-in connector

### Measuring principle

The pressure sensor utilizes an internal piezoelectric transducer to convert the mechanical pressure into a corresponding mV signal. The mV signal then passes through custom linearization and conditioning circuitry. The resulting signal is an industry standard 4...20 mA, according to the specified range. In addition, onboard circuitry handles temperature compensation to ensure a stable reading during all phases of operation.

### Authorizations



### LAR-361

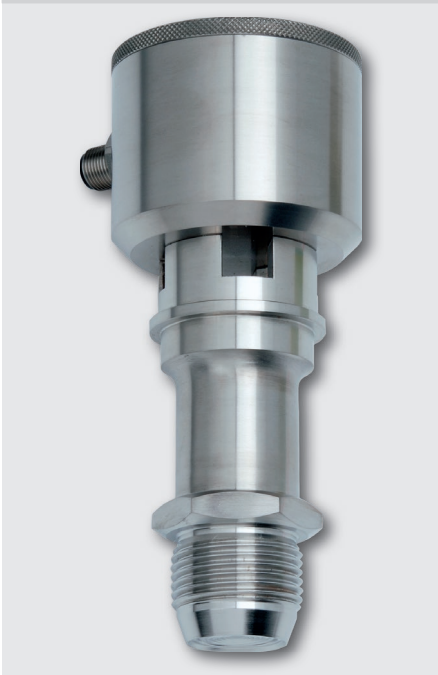

### Measuring principle

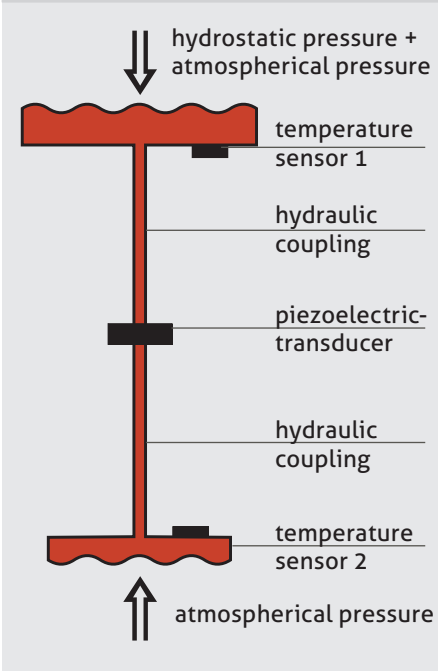

Specification		
Pressure ranges, standard	relativ	0...0.35 / 1.0 / 2.0 / 3.3 / 4.0 bar
Over-range rating	factor	2 times base range
Process connection	LAR-361: <b>CLEANadapt</b>	thread G1" sensor, combined with Negele process connection CLEANadapt torque max. 20 Nm
	LAR-761: <b>DIRECTadapt</b>	Tri-Clamp 1½" or 2", DRD, SMS 38, Dairy flange DN40/50, Endress+Hauser Uni 65/85, Hengesbach PZV/VZR series
Materials	connector head thread connection diaphragm oil filling	SS 316 (1.4305), Ø 65 mm SS 316L (1.4404) SS 316L (1.4404), R <sub>a</sub> < 0.4 µm medical white oil, FDA approval number 21CFR172.878, 21CFR178.3620, 21CFR573.680
Temperature ranges	ambient process compensated CIP-/ SIP-cleaning	-10...+50 °C (15...120 °F) -20...+130 °C (0...265 °F) -20...120 °C (0...250 °F) 140 °C (284 °F) max. 30 minutes
Temperature compensation time	t <sub>90</sub>	30 s / 10 K
Accuracy	hysteresis linearity reproduceability	≤ 0.075 % of full scale ≤ 0.05 % of full scale ≤ 0.075 % of full scale
Temperature drift	zero span	< 0.04 % of full scale / K < 0.04 % of full scale / K
Electrical connection	cable gland cable connection	M16 x 1.5 (PG) M12 plug-in SS 316 (1.4305) (Option)
Protection class		IP 67 (with cable gland) IP 69 K (with M12 plug-in connector)
Supply voltage		12...40 V DC
Output	2-wire current loop	analog 4...20 mA short circuit proof
Max. loop resistance (not incl. LAR)	power supply 18 V DC 24 V DC 40 V DC	max. resistive load 300 Ω 600 Ω 1200 Ω
Weight		approx. 1050 g

#### Pressure ranges

Type	min. operation range	max. operation range	over-range rating
LAR-x61 / 0	0...0.1 bar	0...0.35 bar	0.6 bar
LAR-x61 / 1	0...0.35 bar	0...1.0 bar	2.0 bar
LAR-x61 / 2	0...1.0 bar	0...2.0 bar	4.0 bar
LAR-x61 / 3	0...2.0 bar	0...3.3 bar	6.6 bar
LAR-x61 / 4	0...3.3 bar	0...4.0 bar	8.0 bar

LAR-361 | G1" CLEANadapt

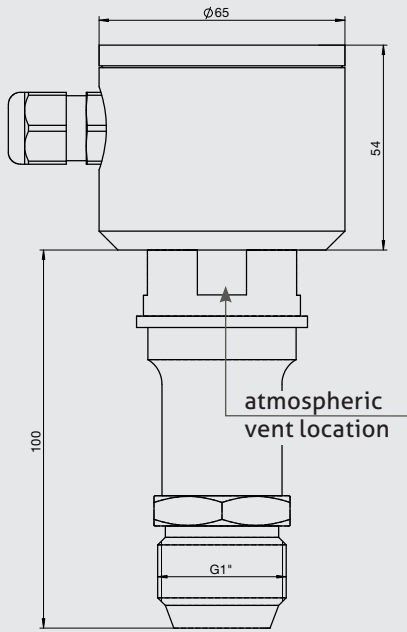

LAR-761 | Dairy flange DIN 11851

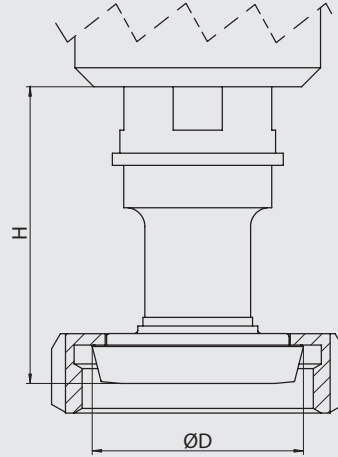

DIN 11851 size

Typ	H	$\varnothing D$
DN40	75.7 mm	55.9 mm
DN50	77.0 mm	68.5 mm

LAR-761 | Tri-Clamp

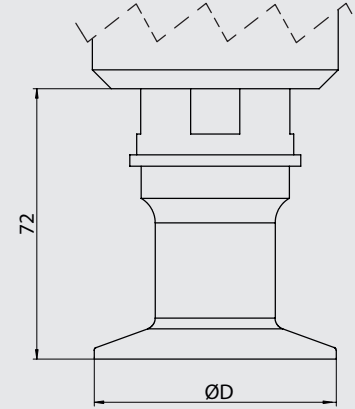

Tri-Clamp size

Type	$\varnothing D$
TC1	50.5 mm
TC2	64.0 mm

LAR-761 | Endress+Hauser (EHS)

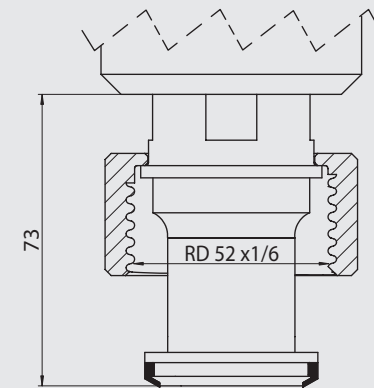

LAR-761 | Endress+Hauser (EHL)

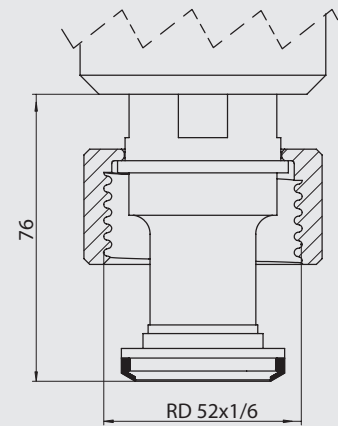

LAR-761 | HPV

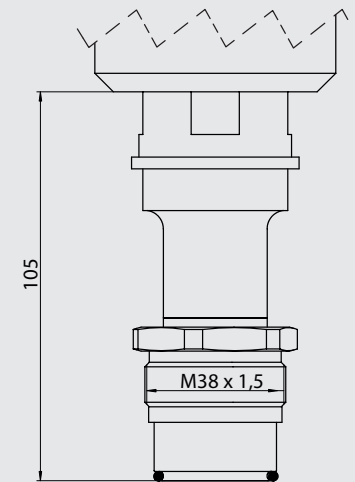

LAR-761 | DRD-65

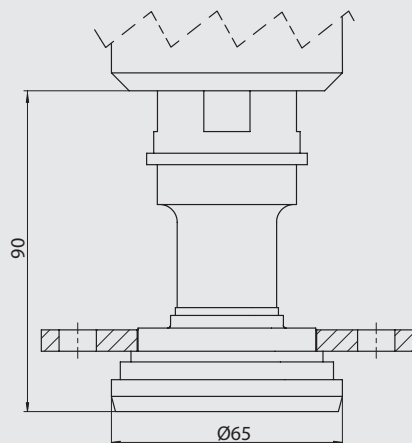

LAR-761 | SMS 38

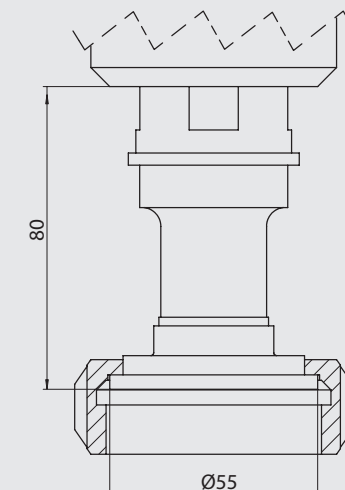

#### Mechanical connection / Installation



- Pay attention to the maximum tightening torque of 20 Nm if using Negele **CLEANadapt** system!
- Pay attention to remain open the 4 ports of atmospheric vent location.

## Electrical connection

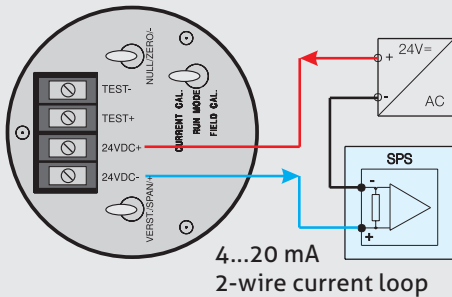

## With M12-plug

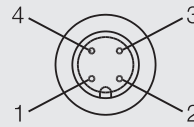

## Configuration M12-plug

- 1: supply +24 V DC
- 2: output 4...20 mA
- 3: not connected
- 4: not connected

## Start up



- Connect the sensor with power supply (12...36VDC) -> see "electrical connection LAR".
- The sensor is now ready for use.
- At standard factory-setting 0...100 % of the full range are equivalent to 4...20 mA of the current output.  
**Example: LAR-xxx/1 = 0...1 bar -> 0 bar = 4 mA; 1 bar = 20 mA**
- In case of specific factory calibration the customized measurement range is equal to 4...20 mA of the current output.  
**Example: LAR-xxx/1 calibrated to 0...0.8 bar -> 0 bar = 4 mA; 0.8 bar = 20 mA**
- Calibration is on-site customizable for special measurement tasks.
- Settings of ZERO (4 mA) and SPAN (20 mA) are non-interactive, having no effect on each other.

## Empty adjustment (with empty vessel)

- After mounting an empty adjustment is **strongly recommended**, because mounting position can affect the ZERO setting.
- Empty vessel completely (no pressure or product on diaphragm, vessel is vented to atmosphere)
- Switch in position "RUN MODE"
- Actuate key switch "ZERO" for 5 seconds
- Empty adjustment is done.
- Output current is 4 mA.
- For maximum accuracy we advice an empty adjustment one more time after 3 weeks.
- After that an annually empty adjustment is recommended.

## Empty adjustment

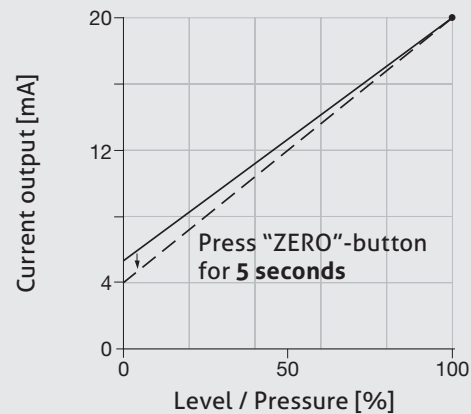

## 1. Full adjustment (with filled vessel utilizing level in vessel)

- Fill vessel to desired maximum level
- Please pay attention that hydrostatic pressure must be between min. and max. range of sensor (see table of pressure ranges page 2).
- Switch in position "RUN MODE"
- Actuate key switch "SPAN" for 5 seconds
- Full adjustment is done.
- Output current is 20 mA

## Full adjustment

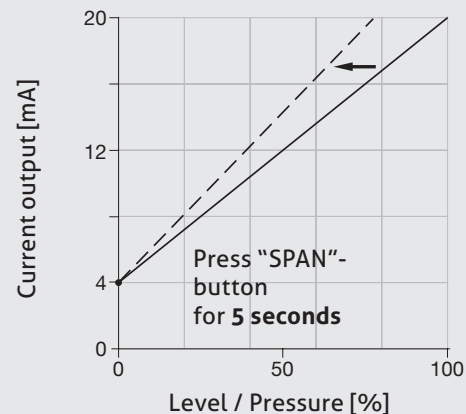

## 2. Utilizing on-board setup

If "wet calibration" (by vessel filling) is not possible, full adjustment can be done by on-board setup. First of all, the desired range (full value) must be calculated to a corresponding current value. Afterwards, the calculated current will be adjusted by multimeter to perform new calibration. In the following, a current calibration procedure is described as an example.

### Calibration hookup

Multimeter

4...20 mA  
2-wire current loop

### LAR calibration values

Type	Base range in bar	Upper linearization value in bar	Current CAL at base range in mA
LAR- $\chi$ 61/0	0.35	0.3612	19.50
LAR- $\chi$ 61/1	1.00	1.0462	19.29
LAR- $\chi$ 61/2	2.00	2.0799	19.39
LAR- $\chi$ 61/3	3.30	3.4623	19.25
LAR- $\chi$ 61/4	4.00	4.0228	19.91

### 2.1 Calculating the current to adjust

For calculating the current to adjust the "upper linearization value" is needed (see table calibration values). This linearization value is greater than the base range. LAR needs this value to calculate the characteristic line.

Calculation formula:

$$(( \text{desired range} / \text{upper linearisation value} ) \times 16) + 4 = \text{current to adjust}$$

Example:

LAR-361/1 needs to be calibrated to 0.8 bar:  $(( 0.8 / 1.0462 ) \times 16) + 4 = 16.23 \text{ mA}$

### 2.2 LAR adjustment

- Connect LAR with power supply -> see figure calibration hookup above.
- Perform meter hookup with test points (setting mA/DC).
- Set MODE SWITCH to "FIELD CAL".
- Meter output will automatically move to 19.99 mA – LAR is waiting for entry of new calibration range.
- Using the switches "SPAN" and "ZERO", raise or lower the current until the calculated value (see above) has been reached. (The longer the switches are pressed the faster changes the current value.)
- Once the proper value has been reached, simultaneously depress both the "SPAN" and the "ZERO" switch for one second – this will lock in new sensor calibration.
- Place MODE SWITCH in "CURRENT CAL" position and verify meter is reading calculated value. (When switching to "CURRENT CAL" position, current output is equal to actual calibration).
- Set MODE SWITCH to "RUN MODE"
- LAR is now ready for use with new calibration setting.

### 2.3 Reset to factory setting

If factory reset to base range is needed, perform calibration shown in procedure 2.2 and adjust current acc. to table "LAR calibration values" (CURRENT CAL at base range).

### Hydrostatic Level Measurement and Linearization with LAR and PEM-DD

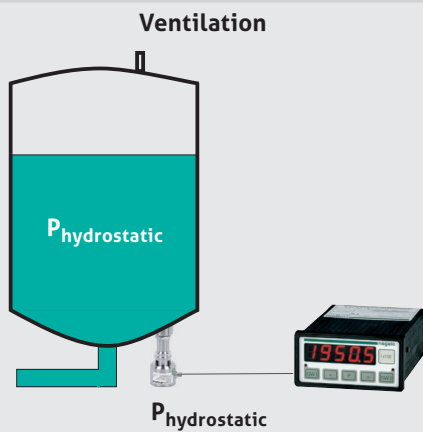

### Difference Pressure Measurement and Linearization with 2 x LAR and PEM-DD

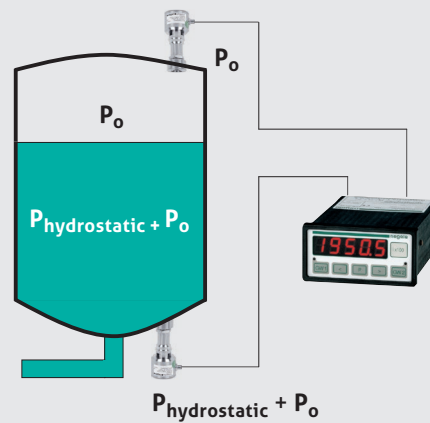

$$P_{\text{difference}} = (P_{\text{hydrostatic}} + P_o) - P_o$$

$$P_{\text{difference}} = P_{\text{hydrostatic}}$$

### Advice for differential pressure measurement in pressurized vessels



$$P_o < 4 \times P_{\text{hydrostatic}}$$

To guarantee a stable differential pressure measurement in pressurized vessels the overpressure must not be higher than 4 times of the hydrostatic pressure!

### Cleaning



- Cleaning with fluids does not effect operation
- Metal diaphragm (process and reference) mustn't be cleaned mechanically
- In case of using pressure washers, don't point nozzle directly to electrical connection or reference diaphragm (atmospheric vent location)!
- In case of inside cleaning with pressure washers, don't point nozzle directly to the diaphragm!

### Advice to EMC



- Applicable directives: Electromagnetic Compatibility Equipment Directive 2004/108/EC
- The CE label confirms compliance of this product with the applicable EC directives.
- The operator is responsible for ensuring compliance with the directives that are applicable to the overall system.

### Conventional Usage



- Not suitable for applications in explosive areas.
- Not suitable for applications in security-relevant equipments (SIL).

### Reshipment



- Sensors shall be clean and must not be contaminated with dangerous media! Note the advice for cleaning!
- Use suitable transport packaging only to avoid damage of the equipment!

### Transport / Storage



- No outdoor storage
- Dry and dust free
- Not exposed to corrosive media
- Protected against solar radiation
- Avoiding mechanical shock and vibration
- Storage temperature 0...40 °C
- Relative humidity max. 80 %

### Disposal



- This instrument is not subject to the WEEE directive 2002/96/EC and the respective national laws.
- Pass the instrument directly on to a specialised recycling company and do not use the municipal collecting points.



Troubleshooting	
Symptom	Action
1. No output current (0 mA) in any Mode.	Loop may be broken - Measure voltage across LOOP+ and LOOP- terminals. If not between 12...40 V DC, check connector and external loop wiring. Check if mA fuse in DMM is blown. This frequently occurs during testing.
2. Current output less than 4 mA and does not increase with level, or if mode switch set to „FIELD CAL“.	Connect milliammeter across LOOP+ terminal and TEST-testpoint. If loop now works, sensor circuitry has been damaged. Contact factory.
3. Output stuck between 4 and 20 mA	Verify that MODE switch is in RUN mode. Empty vessel and perform Sensor Rezero procedure as described on page 4.
4. Performing sensor rezero procedure does not return output to 3.96...4.04 mA	Verify that CUR CAL output is between 7.2 and 20 mA. If current is less than 4 mA, follow instructions for Symptom No. 2. If current is greater than 4 mA, sensor is damaged. Contact factory.
5. Sensor output is not stable. 6. Output drifts over time.	Verify that CUR CAL value is between 7.2 and 20 mA. Check for signs of moisture or water in housing. Contact factory.
7. Sensor mA output not as expected for specified level. 8. Output signals are not accurate.	Perform Sensor Rezero procedure when vessel is empty. Afterwards repeat the full adjustment.
9. Sensor output signal is greater than 20 mA.	Sensor may have been zeroed with product in the vessel. Perform Sensor Rezero Procedure as described on page 4. Sensor maybe over-ranged. Verify CUR CAL value, and that it is appropriate for the application. Contact factory for assistance.
10. Sensor output does not increase with the level, but does increase to 20 mA if mode switch set to „FIELD CAL“.	Sensor may have been dropped or over-ranged and permanently damaged. Contact factory for assistance.

#### Conditions for a measuring point according to 3-A Sanitary Standard 74-06



- The sensors LAR-761 / TC conforming to the 3-A Sanitary Standard.
- The sensors are designed for CIP-/ SIP-cleaning. Maximum 140 °C / 30 minutes.
- Only with 3-A conforming Tri-Clamp connection.
- Mounting position, self draining and the position of the leakage hole must be in accordance to current 3-A Sanitary Standard.

#### Overview of possible process connections for LAR-361.

The complete overview of all available adapters you will find at product information CLEANadapt.

LAR-361					
Process connection	Build-in system EHG (DIN 11850 series 2)	Negele weld-in sleeve	Dairy flange (DIN 11851)	Varivent	APV-Inline

## Order Code

LAR-361  
LAR-761

(Climatic independent level sensor, process connection CLEANadapt G1")  
(Climatic independent level sensor, process connection DIRECTadapt)

## Measuring range (relative)

0	(0...0.35 bar)
1	(0...1.0 bar)
2	(0...2.0 bar)
3	(0...3.3 bar)
4	(0...4.0 bar)

## Process connection (only for LAR-761)

TC1	(Tri-Clamp 1½", incl. 3-A TPV verification acc. to standard 74-06)
TC2	(Tri-Clamp 2", incl. 3-A TPV verification acc. to standard 74-06)
D40	(Dairy Flange DIN 11851 DN40)
D50	(Dairy Flange DIN 11851 DN50)
DRD	(DRD Flange 65 mm)
SM3	(SMS 38 mm with union nut)
EHL	(Endress+Hauser universal adapter Uni 65 6" D85)
EHS	(Endress+Hauser universal adapter Uni 65 / Uni 85)
HPV	(HENGESBACH PZM/VRM series)

## Range adjustment ex works

X	(no adjustment)
[end value]	(please specify required range in "bar")

## Electrical connection

X	(cable gland M16x1.5)
M12	(M12-plug 1.4305)

LAR-361 /

1 /

/

0.5 /

M12

## Accessories

**PVC-cable with M12-connection made of 1.4305, IP 69 K, unshielded**  
M12-PVC / 4-5 m PVC-cable 4-pin, length 5 m  
M12-PVC / 4-10 m PVC-cable 4-pin, length 10 m  
M12-PVC / 4-25 m PVC-cable 4-pin, length 25 m

**PVC-cable with M12-connection, brass nickel-plated, IP 67, shielded**  
M12-PVC / 4G-5 m PVC-cable 4-pin, length 5 m  
M12-PVC / 4G-10 m PVC-cable 4-pin, length 10 m  
M12-PVC / 4G-25 m PVC-cable 4-pin, length 25 m

**M12-EVK** M12 plug-in screw cap, 1.4305 (303), with o-ring, as a protection against humidity and dirt

**CERT / 2.2 / LAR** factory certificate 2.2 acc. to EN10204 (only product contacting surface)

**CERT / 3.1 / LAR** inspection certificate 3.1 acc. to EN10204 (only product contacting surface)

## PVC-cable with M12-connection



## M12 plug-in screw cap

