

Product Information ITM-51 | ITM-51R

FOOD

Relative Turbidity Meter ITM-51



Application / Specified Usage

- Relative turbidity measurement of liquid media for mid to high turbidity range (200...300,000 NTU equivalent)

Application Examples

- Phase separation of products (for example whey – cream – milk)
- CIP-return line (monitoring of pre-rinse water to product leftovers)
- Yeast harvest in breweries
- Quality control
- Leakage control of filter and gaskets

Hygienic Design / Process Connection

- By using Negele weld-in sleeves / adapters of the CLEANadapt system or the build-in system EHG-.../ 1/2" a flow optimized, hygienic and easy sterilizable installation will be achieved.
- CIP-/SIP-cleaning up to 140 °C / maximum 120 minutes
- Product contacting materials compliant to FDA
- Sensor made of stainless steel
- Optics made of high resistant sapphire
- Process connection G1/2" hygienic, Tri-Clamp or Varivent, adapters available for milk pipe (DIN 11851), DRD, APV et al. (see CLEANadapt product information)
- 3-A compliant Tri-Clamp process connection

Features / Advantages

- Front flush sensor
- Independent to reflexions at small diameters or electro-polished surfaces
- No color dependency (wave length 860 nm)
- Smallest pipe diameter: DN 25
- High reproducibility: $\leq 1\%$ of full scale
- Switching output (switchpoint and hysteresis freely adjustable)
- Analog output 4...20 mA freely adjustable
- Two ranges externally switchable

Options / Accessories

- Electrical connection with M12 plug-in connector
- Preassembled cable for M12 plug-in connector
- Display module Simple User Interface (SUI) and Large User Interface (LUI)
- Remote version with cable length up to 30 m

Measuring Principle of the Relative Turbidity Meter

An infrared diode irradiates infrared light into the media. Particles in the media reflecting the irradiated light which is detected by the receiver diode (backscatter principle). The electronics calculates the relative turbidity of the media according to the received signal.

The relative turbidity is based on the Negele calibration standard and is displayed in "%TU".

Authorizations



ITM-51



ITM-51R



Measurement Principle

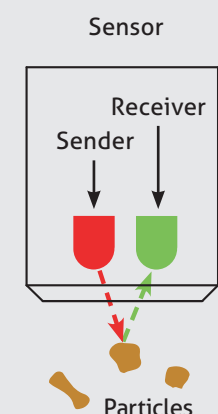

Specification			
Measurement category	can be selected	%TU, NTU, EBC, %solids (customized)	
Measurement range	freely adjustable	0...300,000 NTU equivalent 0...200 %TU 0...75,000 EBC	
Process connection		CLEANadapt G1/2" hygienic TriClamp 1.5", 2", 2.5", 3" Varivent DN 25 (type F) DN 40/50 (type N)	
Process pressure		-1...20 bar	
Tightening torque		20 Nm (CLEANadapt system)	
Materials	Connecting head Sensor Lens Plastic cover/sight glass	Stainless steel 1.4308 Stainless steel 1.4404 (316L) Sapphire Polycarbonate	
Temperature ranges	Ambient Process CIP/SIP	-10...60 °C -10...130 °C Up to 140 °C max. 120 min	
Reproducibility	of turbidity	< 1% of upper range limit	
Resolution/measurement range	the resolution is dependent on the selected measurement range	range/NTU	resolution/NTU
		< 1000	15
		1000...10000	30
		10000...100000	100
Accuracy	0...9,999 NTU 10,000...300,000 NTU	±3% from measurement value; ±50 NTU offset ±5% from measurement value	
Long-term stability	±0.2%	from measurement value	
Response time	for turbidity measurement	0.75 s	
Damping	1.5 s, 3 s, 5 s, 10 s, 20 s	adjustable damping	
Measurement principle	Infrared backscatter	wave length 860 nm	
Electrical connection	Cable gland Cable connection Supply voltage Protection class	2 x M16x1.5 2 x M12 connector 1.4305 18...36 V DC max. 190mA IP69K	
Output	1 analog outputs 1 switching output	4...20 mA (scaled to measurement range) potential free switching output	
Weight		750 g	

Mechanical Connection / Installation



- The sensor has to be installed in that way that the sensor tip is entirely washed around by media and no bubbles can occur. Installation in a rising pipe is recommended.
- If weld-in sleeve is correctly mounted the axis between the 2 connectors points in flow direction.
- For installation in horizontal pipes from top the standard sensor with 15 mm sensor tip is recommended to avoid the influence of bubbles to the measuring signal.
- Attention: The maximum tightening torque for mounting is 20 Nm!

Conditions for a measuring point according to 3-A Sanitary Standard 46-03



- The Sensors ITM-51 / ITM-51R with process connection TCx and TLx are conforming to the 3-A Sanitary Standard.
- Sensors are designed for CIP-/SIP cleaning. Maximum 140 °C / 120 min.
- An internal leakage monitoring is indicating liquid ingress into the sensor body (refer to manual)
- The mounting position, self-draining properties and position of the leakage hole must be in accordance with the current 3-A Sanitary Standard.

ITM-51 with vertical head orientation

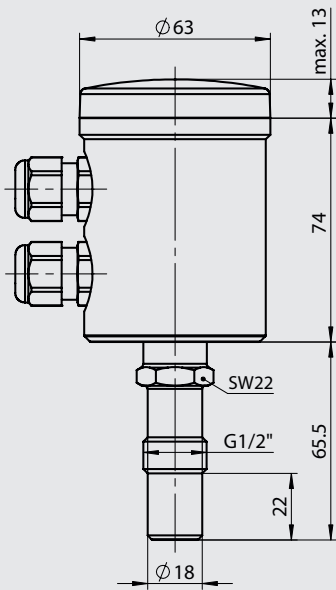

ITM-51-SOL-V-D-P

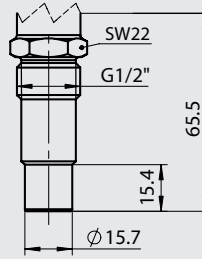

ITM-51-TCx-V-D-P

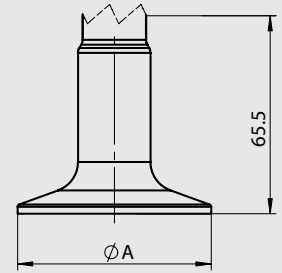

ITM-51-TLx-V-D-P

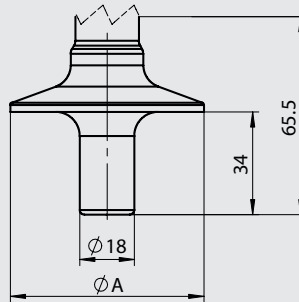

ITM-51-Vxx-V-D-P

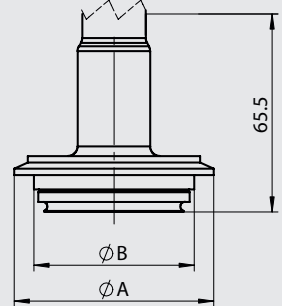

ITM-51 with horizontal head orientation

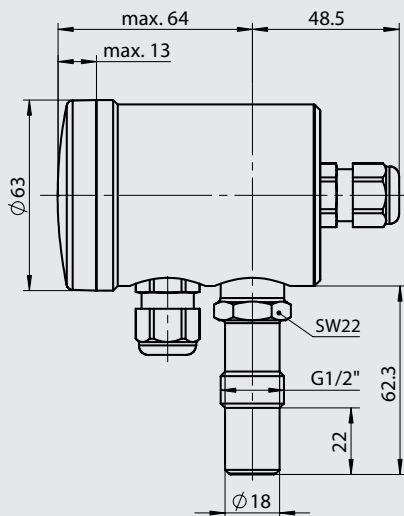

ITM-51-SOL-H-D-P

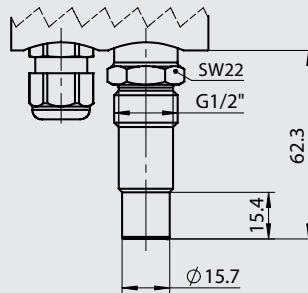

ITM-51-TCx-H-D-P

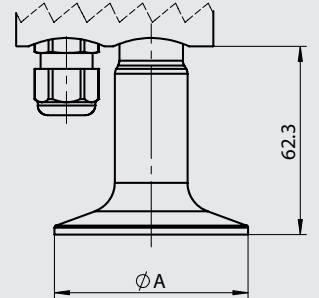

ITM-51-Vxx-H-D-P

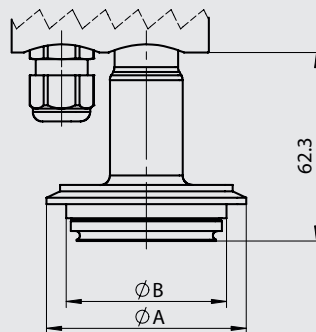

ITM-51-TLx-H-D-P

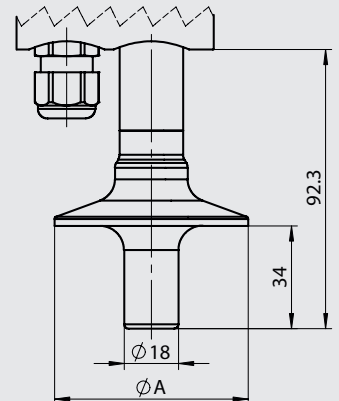

Varivent size

Type	Ø A	Ø B
V25	66.0 mm	57.0 mm
T40	84.0 mm	75.0 mm

Tri-Clamp size

Type	Ø A
TC1/TL1	50.5 mm
TC2/TL2	64.0 mm
T25/TL5	77.5 mm
TC3/TL3	91.0 mm

HUR / Head Unit Remote Version

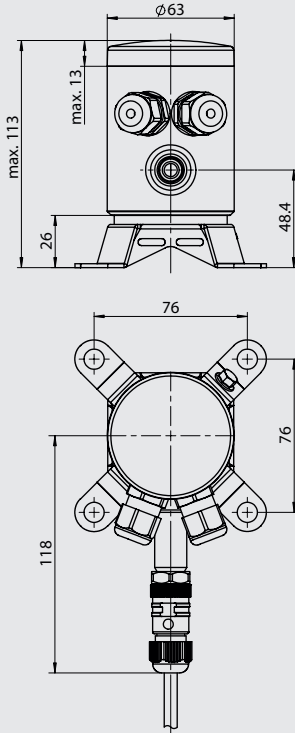

ITM-51R-SO1-D-P

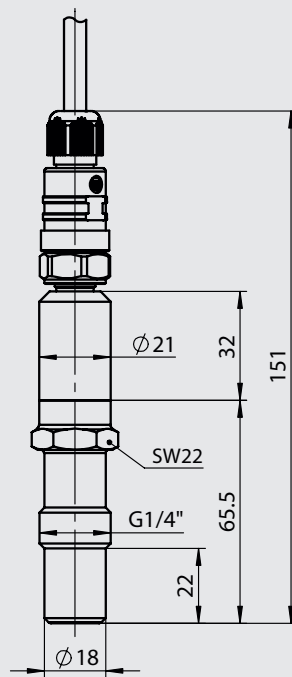

ITM-51R-SOL-D-P

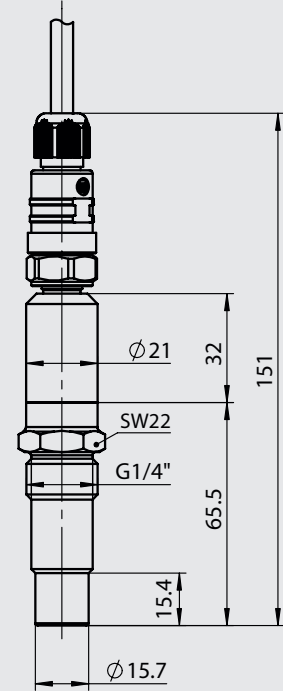

ITM-51R-Vxx-D-P

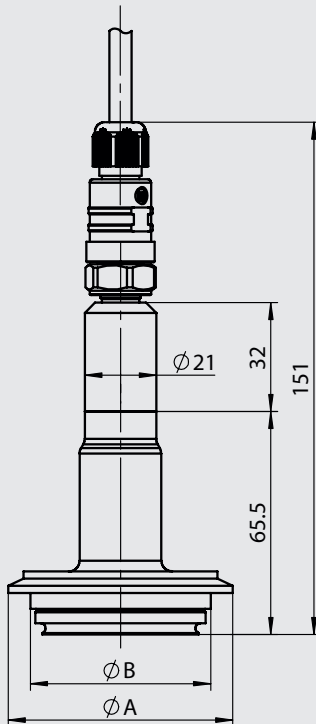

ITM-51R-TCx-D-P

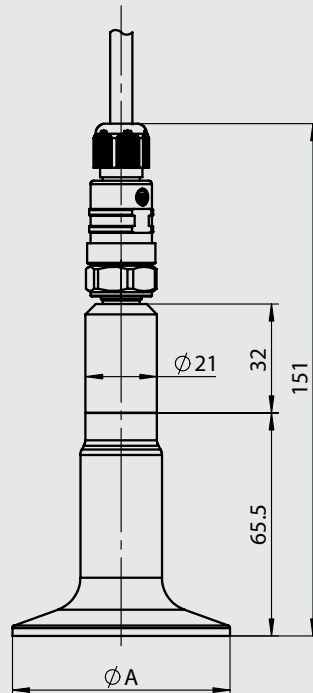

ITM-51R-TLx-D-P

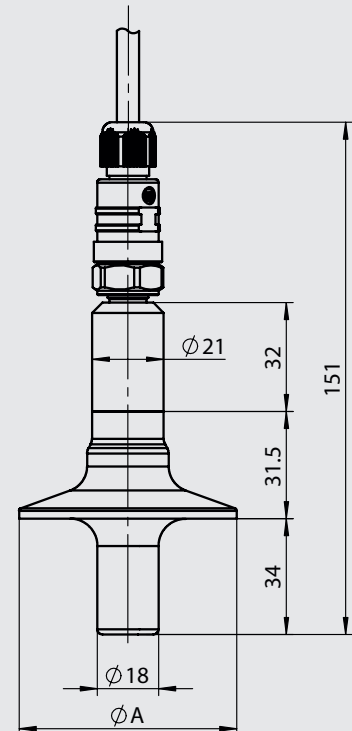

Disposal



- This instrument is not subject to the WEEE directive 2002/96/EG and the respective national laws.
- Pass the instrument directly on to a specialised recycling company and do not use the municipal collecting points.

Reshipment



- Sensors shall be clean and must not be contaminated with dangerous media! Please note the advice for cleaning on page 5!
- Use suitable transport packaging only to avoid damage of the equipment!

Adjustment

- The factory setting of the device is measuring range 1 (0...100 % = 4...20 mA).
- With an external control voltage (24 V DC) range 2 can be selected (E1 = 24 V DC). (See "Electrical Connection")

Switching the Measurement Range

- The digital control input E1 is galvanically isolated from the power supply. Ground: clamp 9 (0 V)

E1*	Measurement Range
0	1 (factory setting: 0...100 %)
1	2 (factory setting: 0...10 %)

* 0 = 0 V DC / 1 = 24 V DC

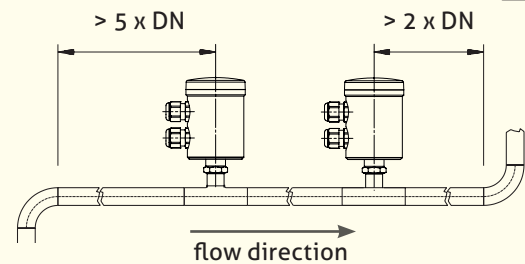
In- and Output Length**Note**

Select suitable measurement range in applications with high turbidity variances (e.g. milk / milk water mixture) for precise measurement!

**Calibration**

Device is calibrated ex works. A periodical calibration is not necessary. A calibration check can be performed on site by using the calibration check tool. For detailed description please refer to the manual.

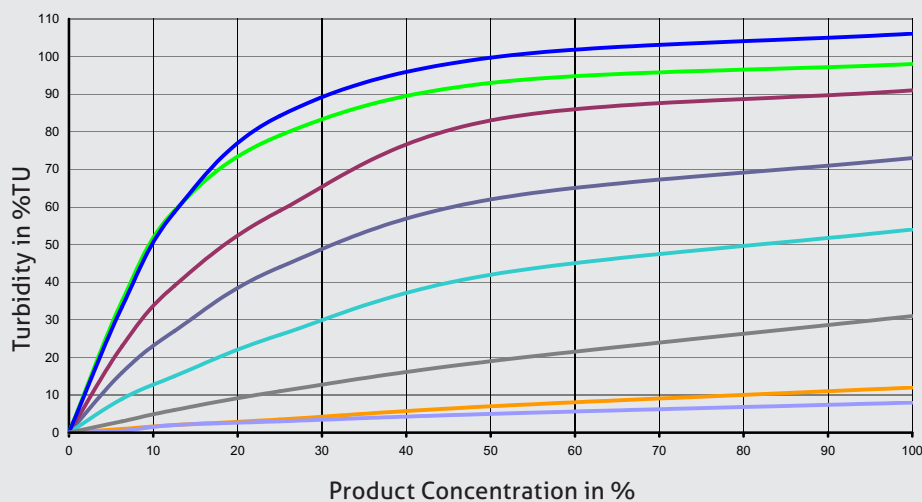
**Showcase Diagram of different Media**

Cream (40 % fat)*
 Cream (32 % fat)*
 Cream (10 % fat)*
 Full Cream Milk (3.5 % fat)*
 UHT-Milk (1.5 % fat)*
 Whey*
 Tomato Juice
 Orange Juice

* Average turbidity of customary milk products at different dilutions.

Turbidity Diagram

Depending on particle form and size, the slope of the characteristic curve is decreasing while turbidity is increasing. This is primarily caused by dampening / absorption effects due to multiple reflections inside the media. The turbidity measured in the production process can deviate from the graphs shown above, depending on product, process step and production process.

**Cleaning / Maintenance**

- Don't use sharp items or aggressive detergents for cleaning the optics.
- In case of using pressure washers, don't point nozzle directly to electrical connections!

**Conventional Usage**

- Not suitable for applications in explosive areas.
- Not suitable for applications in security-relevant equipments (SIL).



Electrical Connection ITM-51 | ITM-51R

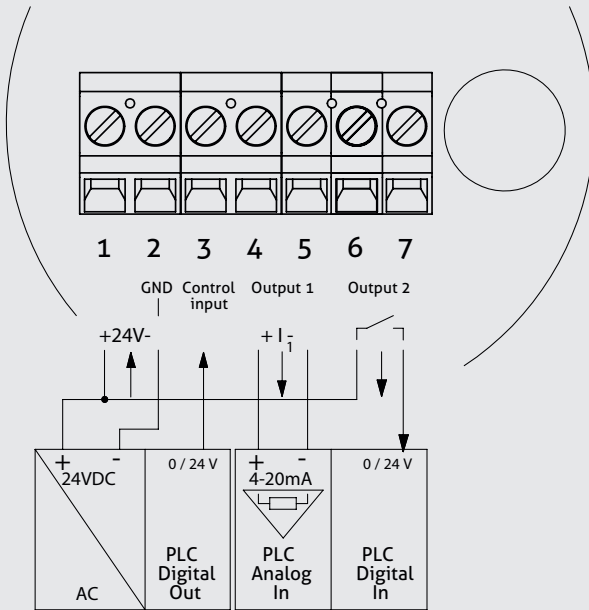

- 1: Power supply +24 V DC
- 2: Power supply -
- 3: Digital input E1
- 4: Output 1 +
- 5: Output 1 -
- 6: Output 2 +
- 7: Output 2 -

Parameterization

The turbidity meter ITM-51 / ITM-51R is set to operate without requiring special settings. Should the parameters need to be changed, this can be performed using the PC-based MPI-200 programming adapter or the User Interface. For further details please refer to the operating manual.

Programming adapter MPI-200-F connection

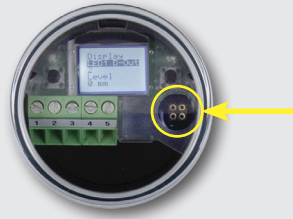

Connection plug for MPI-200-F adapter as an intermediate plug between the ITM-51 electronics and the MPI-200 connection 3 (see next figure).

Connection of programming adapter MPI-200

- 1: Connection for M12 connector
- 2: USB port for connecting to a PC
- 3: Connection cable to adapter for ITM-51

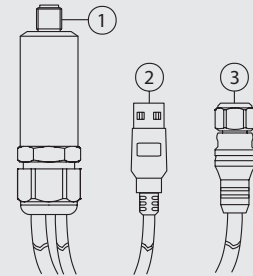

Electrical connection "N" (Output "A53")

M12 connector top (4 pin)

- 1: Out 1 +
- 2: Out - / D out
- 3: Out + / D out
- 4: Out 1 -

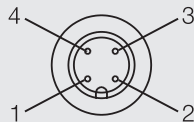

Electrical connection "A" (Output "A53")

M12 connector top (4 pin)

- 1: Out +
- 2: Out -
- 3: Power supply +24 V DC
- 4: Power supply -

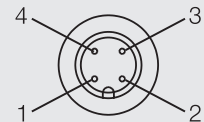

M12 connector bottom (5 pin)

- 1: Power supply +24 V DC
- 2: Not assigned
- 3: Not assigned
- 4: Power supply -
- 5: Digital input (na at A52)

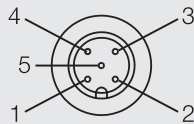

M12 connector bottom (5 pin)

- 1: Out - / D out
- 2: Not assigned
- 3: Not assigned
- 4: Out + / D out
- 5: Digital input (na at A52)

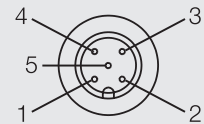

Electrical connection "M" (Output "A42")

M12 connector top (4 pin)

- 1: Power supply +24 V DC
- 2: Out +
- 3: Out -
- 4: Power supply -

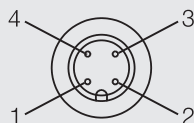

Order code

ITM-51R (relative turbidity meter, remote version, remote cable must be ordered separately)

Process connection

S0L	(CLEANadapt G1/2", 15 mm sensor tip)
S01	(CLEANadapt G1/2", frontflush)
TC1	(Tri-Clamp 1½")
TC2	(Tri-Clamp 2")
T25	(Tri-Clamp 2½")
TC3	(Tri-Clamp 3")
TL1	(Tri-Clamp 1½", long)
TL2	(Tri-Clamp 2", long)
TL5	(Tri-Clamp 2½", long)
TL3	(Tri-Clamp 3", long)
V25	(Varivent type F, DN 25)
V40	(Varivent type N, DN 40/50)
XXX	(further process connections on request)

Output

A42	(1 x 4...20 mA turbidity only, display prepared)
A52	(1 x 4...20 mA turbidity, 1 x switching out, no external range switching, display prepared)
A53	(1 x 4...20 mA turbidity, 1 x switching out, external range switching, display prepared)

Electrical connection

P	(cable gland M16x1.5)
D	(2 x cable gland M16x1.5)
M	(1 x M12 connector, 4 pin for output A42, 5 pin for output A5x)
N	(2 x M12 plug, standard)
A	(2 x M12 plug, 4 pin, power/output, 5 pin output/input)

Interface/Display

X	(without Interface)
L	(Large User Interface with display)

Enclosure

X	(opaque plastic cap)
P	(clear plastic cap)
M	(without control window)
W	(with control window)

Parameter configuration

X	(standard)
S	(write out details)

ITM-51R / S01 / A53 / N / L / P / X

Connection cable for ITM-51R (remote version)

M12-PVC/8-5 m	PVC-cable M12 coupling both-sided, 8-pin, IP69K, 5 m
M12-PVC/8-10 m	PVC-cable M12 coupling both-sided, 8-pin, IP69K, 10 m
M12-PVC/8-25 m	PVC-cable M12 coupling both-sided, 8-pin, IP69K, 25 m
M12-PVC/8-xx m	PVC-cable M12 coupling both-sided, 8-pin, IP69K, special length

PVC-cable with M12-connection**Information**

The components ITM-51S/sensor and HUR/Head Unit Remote can be purchased as spare parts separately. The valid configuration can be seen on the product labels.



Order code

ITM-51 (relative turbidity meter)

Process connection

S0L (CLEANadapt G1/2", 15 mm sensor tip)
S01 (CLEANadapt G1/2", frontflush)
TC1 (Tri-Clamp 1½")
TC2 (Tri-Clamp 2")
T25 (Tri-Clamp 2½")
TC3 (Tri-Clamp 3")
TL1 (Tri-Clamp 1½", long)
TL2 (Tri-Clamp 2", long)
TL5 (Tri-Clamp 2½", long)
TL3 (Tri-Clamp 3", long)
V25 (Varivent type F, DN 25)
V40 (Varivent type N, DN 40/50)
XXX (further process connections on request)

Enclosure Orientation

H (horizontal)
V (vertical)

Output

A42 (1 x 4...20 mA turbidity only, display prepared)
A52 (1 x 4...20 mA turbidity, 1 x switching out, no external range switching, display prepared)
A53 (1 x 4...20 mA turbidity, 1 x switching out, external range switching, display prepared)

Electrical connection

P (cable gland M16x1.5)
D (2 x cable gland M16x1.5)
M (1 x M12 connector, 4-pin for output A42, 5-pin for output A5x)
N (2 x M12 plug, standard)
A (2 x M12 plug, 4-pin, power/output, 5-pin output/input)

Interface/Display

X (without Interface)
S (Simple User Interface with small display)
L (Large User Interface with display)

Enclosure

X (opaque plastic cap)
P (clear plastic cap)
M (without control window)
W (with control window)

Parameter configuration

X (standard)
S (write out details)

ITM-51 S01 / V / A53 / D / L / P / X

Transport / Storage

- No outdoor storage
- Dry and dust free
- Not exposed to corrosive media
- Protected against solar radiation
- Avoiding mechanical shock and vibration
- Storage temperature -20...+60 °C
- Relative humidity max. 80 %



Notice on conformity

- Applicable directives:
- Electromagnetic Compatibility Directive 2014/30/EC
 - The CE label confirms compliance of this product with the applicable EC directives.
 - You have to guarantee the compliance of all guidelines applicable for the entire equipment.

