

Ultrasonic flow switch FWS-141, FWA-141

Application

- Monitoring of flowing liquids in pipes
- Rough measurement of flow rates and flow volume
- Suitable for media with turbidity ≥ 1 NTU and particle size $> 50 \mu\text{m}$
e.g.: drinking water, juice (unfiltered), milk, emulsions, CIP-media

Application examples

- Flow monitoring in pipes from DN 25, e.g. for dry-run protection or monitoring of filters or valves
- Because of its very short reaction time and independence from temperature fluctuations and conductivity, the device is ideally suited for monitoring flow rates in CIP processes

Hygienic design/process connection

- By using the Negele weld-in sleeve EMS-132 or the build-in system EHG-.../ 1/2" a front-flush, flow optimized, hygienic and easy-to-clean measurement point is achieved
- Compliant with 3-A Sanitary Standard 74-05
- CIP/SIP cleaning up to 140 °C
- Product contacting materials are FDA compatible
- Sensor is made entirely of stainless steel, sensor tip of PEEK material
- Other connections: DRD, Varivent, APV-Inline, BioControl

Features

- Ultrasonic Doppler principle
- Not influenced by temperature fluctuations and conductivity
- Very short reaction time
- Medium temperature up to 140 °C (optional high temperature version)
- Freely programmable setpoint
- Optional: with analog or frequency output (switchable)
- Indicator switching output with LED

Options/accessories

- Integrated indicator module (AZM) with window in cap
- Electrical connection with M12 plug connector
- Cable ex factory for M12 plug connector

Functional principle

A transmitter (1) sends ultrasound waves into the flowing medium. The ultrasound waves impinge on particles (2), such as sediments, dirt particles or air bubbles, that are moving in the direction of flow. These particles reflect the waves. The receiver now detects the reflected frequency, which has a slight shift because the wavelength was changed by the forward motion of the reflecting particle. The frequency difference between the sent and received frequencies is a measure of the speed of the particle and thus also of the flow rate.

Authorizations



FWS-141/M12, FWA-141/M12



Indicator module AZM



Schematic drawing

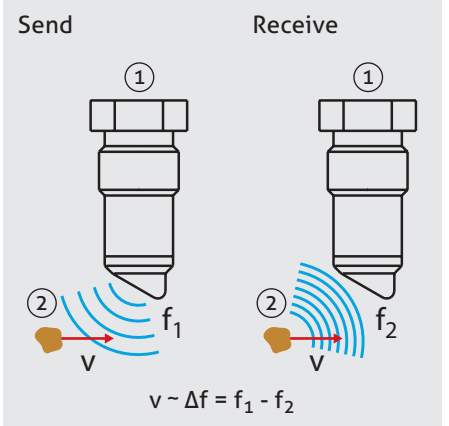

Specification		
Process connection	thread	G1/2" CLEANadapt; combined with Negele weld-in sleeves, build-in systems, adapter sleeves
	torque	max. 20 Nm
Materials	head	stainless steel 1.4305
	connecting thread	stainless steel 1.4404 (316L)
	coupling part	PEEK R _a ≤0.8 μm (FDA number: 21CFR177.2415)
Temperature ranges	ambient	-20...+60 °C
	process	0...100 °C
	high temperature version	0...140 °C (option H)
	CIP/SIP cleaning	up to 140 °C
Operating pressure		max. 10 bar
Measurement range		0.1...2.5 m/s is equivalent to 100%
Indicator (optional)		0...100% of full scale
Accuracy		±10% of full scale acc. to reference conditions*
Reproducibility		<2% of full scale
Damping	FWS	1 s
Hysteresis	FWS	0.2 m/s
Temperature drift	zero, span	<0.02% of full scale /K
Supply		18...36 V DC
Output	FWS	p-switching (active 25 mA, short-circuit proof)
	FWA analog (switchable)	current 4...20 mA frequency 0...1 kHz, square-pulse 18 V DC, ohmic resistance 3...10 kΩ
Electrical connection	cable entry	PG (M16x1.5), 2-pin terminals 1.5 mm ²
	cable connection	M12 plug connector, stainless steel 1.4301
Protection class		IP 67 (with cable entry)
		IP 69 K (with cable connection)
Weight		ca. 485 g
Approvals	hygiene/cleanability	3-A TPV 74-05/EHEDG (CLEANadapt process connection)

* **Reference conditions:**

The calibration medium is water at ambient temperature; turbidity >1 NTU; particle size >50 μm; pipe diameter DN 25.

Conditions for a measuring point according to 3-A Sanitary Standard 74-05



- The sensors FWS-141 and FWA-141 are compliant with the 3-A Sanitary Standard.
- The sensors are designed for CIP/SIP cleaning. Maximum 140 °C for 120 minutes.
- Only permissible in conjunction with the build-in system **CLEANadapt** (EMZ, EMK, EHG with pipe diameter > DN25, ISO 20 and 1", adapters AMC and AMV) allowed.
- When using the weld-in sleeve EMZ or EMK the weld must comply with the requirements of the current 3-A Sanitary Standard.
- The mounting position must be self-draining and the position of the leakage hole must be in accordance with the current 3-A Sanitary Standard.

FWS-141, FWA-141

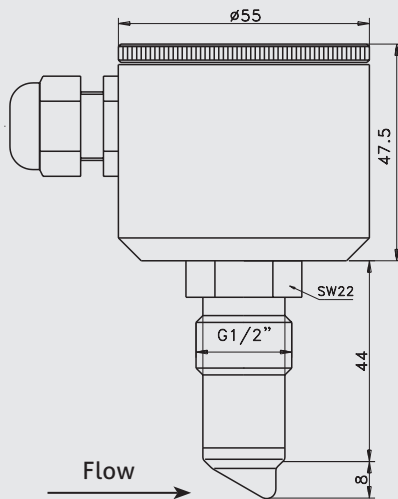

Mechanical connection/installation



- **Attention:** The cable entry must point in the pipe direction and against the direction of flow!
- Note the marking on the sleeve (marking = cable connection).
- At the sensor mounting point, the pipe must be completely filled with liquid. Therefore, it is recommended that the device be fitted in the rising pipe (upward flow direction).
- Due to the measurement principle, it is not possible to use more than one FWA-141 or FWS-141 device in one pipe.
- Note that the feed-in is 5x the pipe diameter, and the feed-out is 2x the pipe diameter.

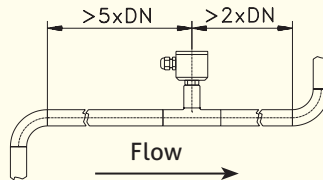

FWS-141, FWA-141 with option -H

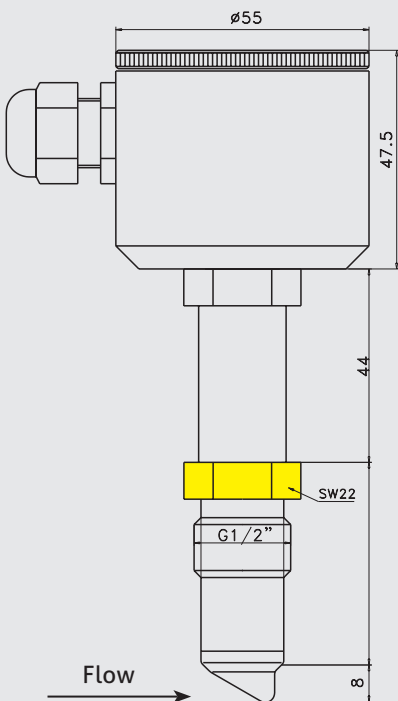

Connecting diagram

- 1: Button
- 2: Plug-in for indicator module AZM
- 3: Status LED output
- 4: Evaluation circuit

Connecting diagram (view from top with open lid)

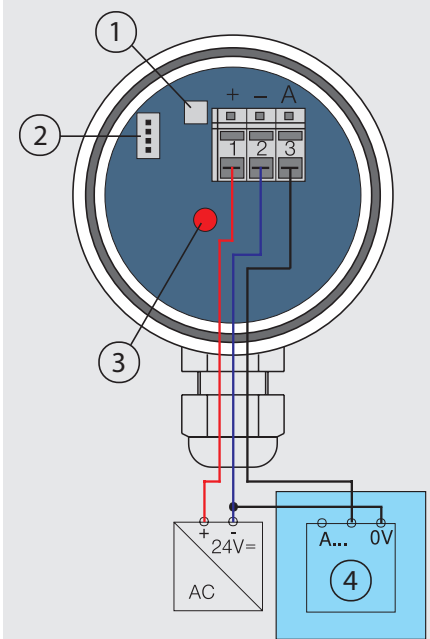

Advice to option -H



Tighten the sensor only at the lower, marked in yellow spanner flat (BE = 22 mm)!

Electrical connection FWS-141

Strip terminal



- 1: + supply 18...36 V DC
- 2: - supply
- 3: output active p-switching

M12 connector

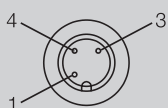

- 1: + supply 18...36 V DC
- 3: - supply
- 4: output active p-switching

Electrical connection FWA-141

Strip terminal



- 1: + supply 18...36 V DC
- 2: - supply
- 3: output analog, frequency

M12connector

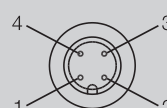

- 1: + supply 18...36 V DC
- 2: output analog, frequency
- 3: - supply
- 4: not connected

1. FWS without indicator module AZM

Teach-in of a setpoint

- Set the flow rate required in the pipe.
- Push the button for 3 s until the LED stops flashing. The setpoint is stored.
- When the setpoint is reached, the LED turns on and the output switches to active.

2. FWS with indicator module AZM

Teach-in of a setpoint

- The indicator shows the actual measurement value in %.
- Set the flow rate required in the pipe.
- Push the button twice briefly; the indicator shows "tEAC" and, after 3 s "Stor".
- Store the setpoint by pushing the button for 3 s. The indicator shows the actual measurement value in %.
- When the setpoint is reached, the LED turns on and the output switches to active.

Manual setting of setpoint

- The indicator shows the actual measurement value as a % of the full measurement range.
- Push the button briefly; the indicator shows "HAnd" and, after 3 s "Stor".
- Push the button for 3 s to select the adjustment mode.
- The indicator shows "P" and the setpoint.
- Pushing the button briefly increments the setpoint in steps of 2%.
- When the required setpoint is reached, wait until the indicator shows "Stor".
- Store the setpoint by pushing the button for 3 s. The indicator shows the actual measurement value in %.
- The setpoint has now been stored and the device can be installed.

3. FWA with/without indicator module AZM

The device is programmed for output mode "A" (analog output 4...20 mA). No further adjustments are required.

If you want to switch to output mode "F" (frequency output 1 kHz) proceed as follows:

- Push the button for 3 s; frequency output is selected. The indicator shows "F" and the LED starts flashing.

Set back to the analog output

- Push the button for 3 s; the indicator shows "A". The analog output mode is now selected and the LED is off.

Service level



Only possible at devices with indicator module AZM.

To check the reflection signal, proceed as follows:

- Disconnect FWS/FWA from the auxiliary voltage
- Press the button and hold it
- Connect the auxiliary voltage and release the button
- The operating hours appear for approx. 2 ... 3 seconds
- Afterwards appears an amplitude value for approx. 40 seconds with preceding "L" at a high amplitude or "H" at a small amplitude.
- If the amplitude value is smaller than "H 40", it will no longer be possible to determine the flow rate because the noise level becomes too high. This is generally the case when the medium does not meet the criteria for measurement (turbidity ≥ 1 NTU, particle size $> 50 \mu\text{m}$).

Conversion table m/s to l/min						
DN	DN 25	DN 40	DN 50	DN 65	DN 80	DN 100
Flow [m/s]	[l/min]	[l/min]	[l/min]	[l/min]	[l/min]	[l/min]
0.1	2.9	7.5	11.8	19.9	30	47
0.2	5.9	15.1	23.6	39.8	60	94
0.4	11.8	30.1	47.1	79.6	121	188
0.6	17.7	45.2	70.7	119.4	181	283
0.8	23.6	60.3	94.2	159.2	241	377
1.0	29.4	75.4	117.8	199.0	301	471
1.2	35.3	90.4	141.3	238.8	362	565
1.4	41.2	105.5	164.9	278.6	422	659
1.6	47.1	120.6	188.4	318.4	482	754
1.8	53.0	135.6	212.0	358.2	543	848
2.0	58.9	150.7	235.5	398.0	603	942
2.2	64.8	165.8	259.1	437.8	663	1036
2.4	70.7	180.9	282.6	477.6	723	1130
2.5	73.6	188.4	294.4	497.5	754	1178

Conversion table in/s to gal/min						
1" =	25.4 mm	25.4 mm	38.1 mm	50.8 mm	76.2 mm	101.6 mm
DN		1"	1½"	2"	3"	4"
[in/s]	[m/s]	[gal/min]	[gal/min]	[gal/min]	[gal/min]	[gal/min]
4.0	0.10	0.82	1.84	3.26	7.34	13.05
8.0	0.20	1.63	3.67	6.53	14.68	26.10
16.0	0.41	3.26	7.34	13.05	29.36	52.20
24.0	0.61	4.89	11.01	19.58	44.05	78.30
32.0	0.81	6.53	14.68	26.10	58.73	104.41
40.0	1.02	8.16	18.35	32.63	73.41	130.51
48.0	1.22	9.79	22.02	39.15	88.09	156.61
56.0	1.42	11.42	25.69	45.68	102.77	182.71
64.0	1.63	13.05	29.36	52.20	117.46	208.81
72.0	1.83	14.68	33.03	58.73	132.14	234.91
80.0	2.03	16.31	36.71	65.25	146.82	261.01
88.0	2.24	17.94	40.38	71.78	161.50	287.12
96.0	2.44	19.58	44.05	78.30	176.18	313.22
100.0	2.54	20.39	45.88	81.57	183.53	326.27

Overview of detectable media		
Medium	detectable/ measurable	not detectable/ not measurable
fluid pastry	x	
drinking water	x	
juice (unfiltered)	x	
milk	x	
beer (in pressure pipe)		x
weiss beer	X	
cola		x
gases		x
CIP media	x	

Intended use







- Not suitable for filtered media with turbidity < 1 NTU, particle size < 50 µm.

Intended use

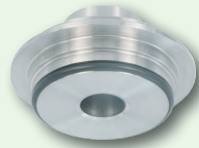

- Not suitable for applications in potentially explosive areas.
- Not suitable for applications in safety-relevant system parts (SIL).

Weld-in sleeves and adapters						
G1/2"						
Diameter		Build-in system EHG (DIN 11850 series 2)	Weld-in ball	Cylindrical sleeve with weld-in ring	Varivent-Inline	APV-Inline
DN25	1"	EHG-DIN2-25 / 1/2"	KEM-132 * (for sloped installation)	EMS-132 * (for installation on pulled-out pipes)	AMV-132/DN25	-
DN32		EHG-DIN2-32 / 1/2"			AMV-132/DN25	-
DN40	1½"	EHG-DIN2-40 / 1/2"			AMV-132/DN40	AMA-132
DN50	2"	EHG-DIN2-50 / 1/2"			AMV-132/DN40	AMA-132
	2½"	-			AMV-132/DN40	-
DN65		EHG-DIN2-65 / 1/2"			AMV-132/DN40	AMA-132
	3"	-			AMV-132/DN40	-
DN80		EHG-DIN2-80 / 1/2"			AMV-132/DN40	AMA-132
DN100		EHG-DIN2-100 / 1/2"			AMV-132/DN40	AMA-132

* Deliverable with material 1.4435 and 3.1 inspection certificate on request.

Cleaning/maintenance

- When using a pressure washer, do not point the nozzle directly at the electrical connections.

Standards and guidelines

- Compliance with the applicable regulations and directives is mandatory.

Transport/storage

- Do not store outside
- Store in an area that is dry and dust-free
- Do not expose to corrosive media
- Protect against solar radiation
- Avoid mechanical shock and vibration
- Storage temperature -20...+60 °C
- Relative humidity max. 80%

Reshipment

- Sensors and process connection must be clean and must not be contaminated with hazardous media and/or heat-conductive paste. Please note the cleaning notice!
- To avoid damage of the equipment, use suitable transport packaging only.

Disposal

- This instrument is not subject to the WEEE directive 2002/96/EC and the respective national laws.
- Give the instrument directly to a specialized recycling company and do not use the municipal collecting points.

Notice on conformity

- Applicable guidelines:
- Electromagnetic Compatibility Equipment Directive 2004/108/EC
 - The CE label confirms compliance of this product with the applicable EC directives.
 - The operator is responsible for ensuring compliance with the directives that are applicable to the overall system.

Order code

FW Ultrasonic flow switch G1/2" CLEANadapt

Signal output

S-141 (with switch output)

A-141 (with analog output)

Display and closing lid

X (without)

AZM (with indicator module AZM incl. window SF in the lid, LC display visible from the outside)

KF (window in the lid, LED visible from the outside)

High-temperature version

X (standard: for process temperatures up to 100 °C)

H (with spacer: for process temperatures up to 140 °C)

Electrical connection

X (cable gland M16x1.5)

M12 (M12 connector 1.4305)

FW **A - 141 /** **AZM /** **H /** **M12**

Accessories

PVC cable with M12 connection made of 1.4305, IP 69 K, unshielded

M12-PVC / 4-5 m PVC cable 4-pin, length 5 m

M12-PVC / 4-10 m PVC cable 4-pin, length 10 m

M12-PVC / 4-25 m PVC cable 4-pin, length 25 m

PVC cable with M12 connection, nickel-plated brass, IP 67, shielded

M12-PVC / 4G-5 m PVC cable 4-pin, length 5 m

M12-PVC / 4G-10 m PVC cable 4-pin, length 10 m

M12-PVC / 4G-25 m PVC cable 4-pin, length 25 m

AZM-55 plug-in display,
for re-fitting of FWS and FWA
(without cap)

AZM-55-SF plug-in display
incl. cap with window
for re-fitting of FWS and FWA

CERT / 2.2 factory certificate 2.2 acc. to EN10204
(product-contacting surface only)

PVC cable with M12 connection



Indicator module AZM and lid with window SF

